

VERT LABLIGHT

LED TECHNOLOGY

Smooth edge at 90°

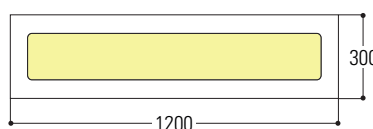
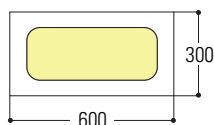
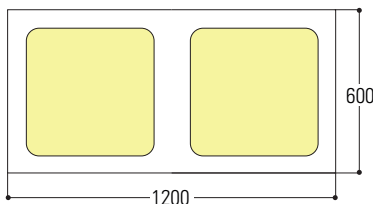
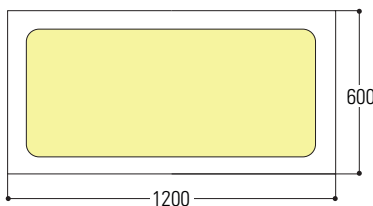
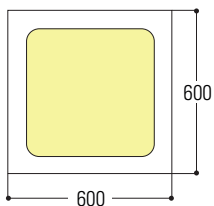
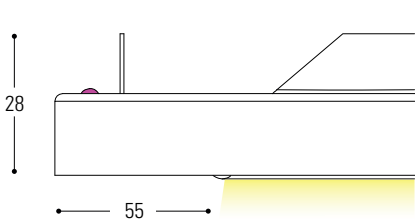

DESCRIPTION

Recessed lighting fixture with high luminous efficiency LED technology. An elegant and modern style guaranteed by the integration inside the Vert Lab type ceiling; unique in its kind it allows installation in ceilings where there is little soffit space. The luminaire consists of an aluminium structure and a cladding panel with the same material (aluminium or steel) and the same finish (pre-painted and post-painted) as the false ceiling, and replaces all applications where fluorescent and halogen tubes were previously used.

TECHNICAL CHARACTERISTICS

Panel material:	Aluminium (Alloy 3000H46) Steel prepainted Steel inox
Ceiling light material	Aluminium (Alloy 3000H46)
Colour:	RAL 9003 o RAL 9010 (with optional antimicrobial paint)
Panel thickness:	0,4 - 0,5 - 0,6 mm
Body thickness:	0,8 mm
Internal driver:	Yes
Features:	DALI module Night light Presence sensor with self-adjustment Emergency module
Standard modules:	600x600 mm with 90° edge 600x1200 mm with 90° edge 300x600 mm with 90° edge 300x1200 mm with 90° edge
Service life:	50.000 hours
LED warranty:	3 Years
Product weight:	4 kg

ADVANTAGES AND APPLICATIONS

Vert Lab System

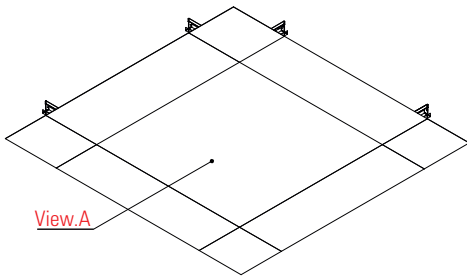

View.A

Vert Lab with ceiling light

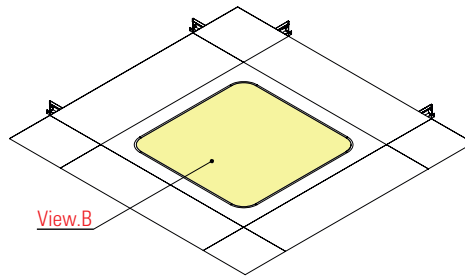

View.B

DESCRIPTION

The Vert Lab Light ceiling light with its modern design allows perfect integration into the Vert Lab system, consisting of a T-shaped structure and a panel that follows the lines and design of the ceiling light, further enhancing the entire mounted system.

The entire system is in a concealed frame and can be accessed from every point by means of a suction cup provided.

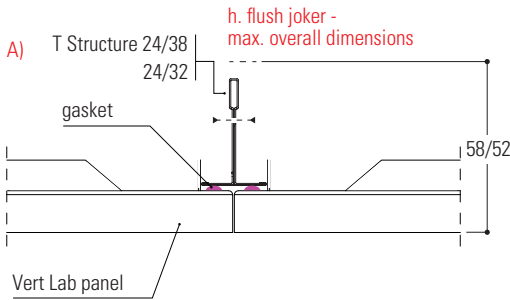

A)

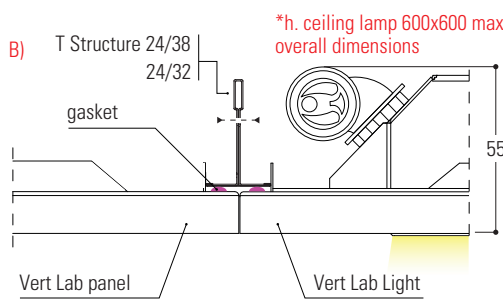

B)

*ceiling light footprint:	module 600x600 55 mm
	module 600x1200 55 mm
	module 300x600 60 mm
	module 300x1200 60 mm

MODULES AND DIMENSIONS

Various solutions are possible; with the possibility of different modules you are able to create the right solution and meet every requirement.

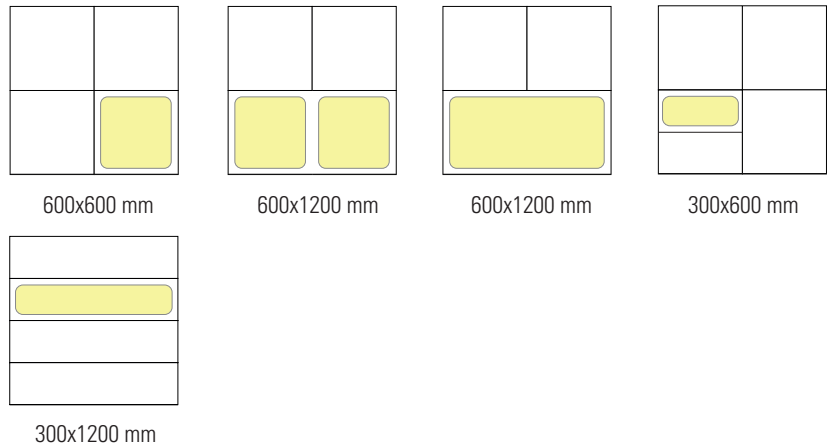
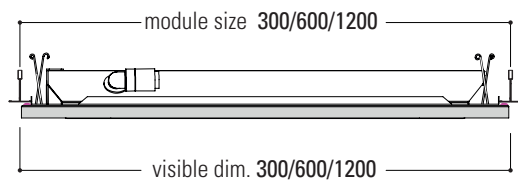

PERFORMANCE AND CONSUMPTION

Vert Lab Light is designed to offer homogeneous, flicker-free lighting suitable for installation in any location where excellent visual performance is required. This LED panel offers excellent lighting performance for up to approximately 50,000 hours, with an estimated daily usage of 8 hours. Thanks to the integrated LED technology, this panel replaces older installations with halogen tubes with significantly lower consumption. The LED system therefore drastically lowers consumption while maintaining the same light intensity.

Type	Dimensions	Power (W)	Luminous flux Lamp** (IM)	Luminous flux Lamp** (IM)
			OPALE	UGR
Vert Lab Light 84	300x600	32	4000	3500
Vert Lab Light 100	600x600	40	3500	3200
Vert Lab Light 144*		55	5300	6000
Vert Lab Light 200		80	7000	6300
Vert Lab Light 265*		89	8800	9800
Vert Lab Light 192	300x1200	70	6300	7500
Vert Lab Light 576	600x1200	-	-	-
Vert Lab Light 100+100	600x1200	80	-	6060

EMERGENCY MODULE

An emergency module can be integrated into the ceiling light, which guarantees a lighting autonomy of up to 3 hours even in the absence of electricity. This module is equipped with the standards shown in the table.

Autonomy	Capacity	Regulations	
3h	4,2 Ah	CEI 61000-6- 3	CEI 2004/108
		CEI EN 6154 7	CE 2006/95
IEC 60598-2-22		CEI EN 61000-4- 8	EN 6052 9

OPTICAL GROUP

- Color rendering CRI>90 (CRI 80 available upon request)
- Photobiological risk 0 (exempt) protected from UV rays EN 62471
- Color temperature 3000K, 4000K and 6000K (LED diode selected 3 steps Mac Adam)
- Useful life (L93/B10): 30000 h. (tq+25°C)
- Useful life (L90/B10): 50000 h. (tq+25°C)
- Useful life (L85/B10): 80000 h. (tq+25°C)

Standard available colour temperature



Available optics:

version UGR<19 (UGR)

Microprismatic polycarbonate optics for environments with video terminals

Standard Version (OP) N.B the OP version is supplied on specific request

Plexiglass LED optics with high light transmission for uniform brightness

CURVE FOTOMETRICHE

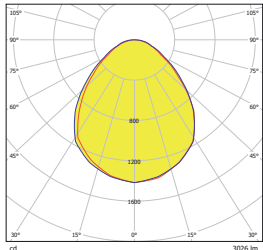

Vert Lab Light 84 32W UGR

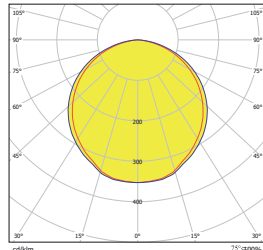

Vert Lab Light 84 38W OP

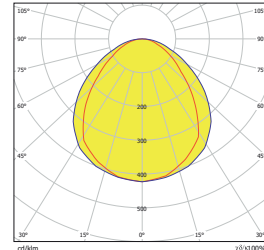

Vert Lab Light 192 70W UGR

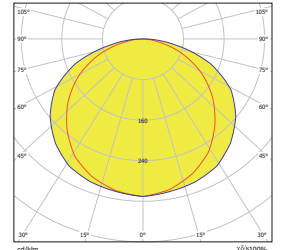

Vert Lab Light 192 75W OP

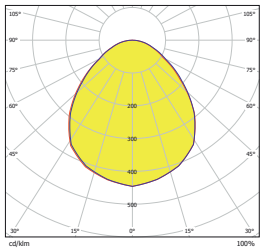

Vert Lab Light 100 40 W UGR

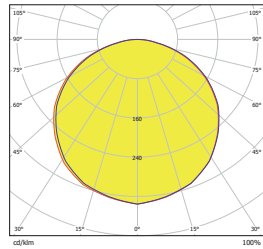

Vert Lab Light 100 40 W OP

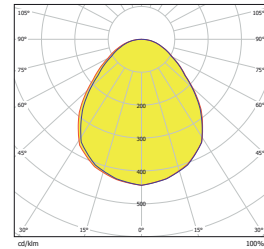

Vert Lab Light 144 55W UGR

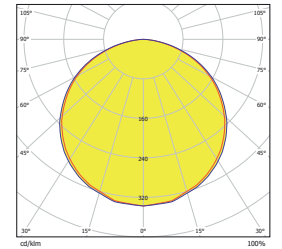

Vert Lab Light 144 56W OP

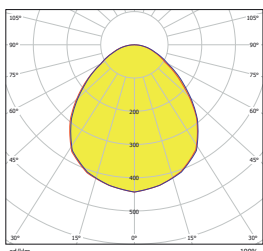

Vert Lab Light 200 80 W UGR

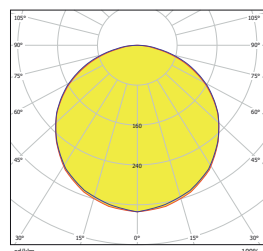

Vert Lab Light 200 80 W OP

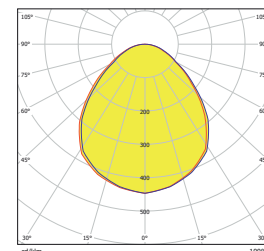

Vert Lab Light 265 89 W UGR

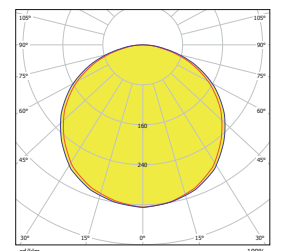

Vert Lab Light 265 90 W OP

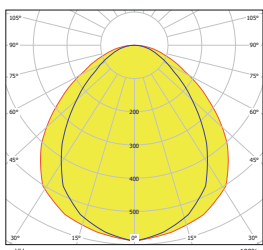

Vert Lab Light 100+100 80 W UGR

SYSTEM ELEMENTS

1. Vert Lab Light
2. Vert Lab Panel
3. T-profile
4. Joker
5. Feeding
6. Harmonic spring

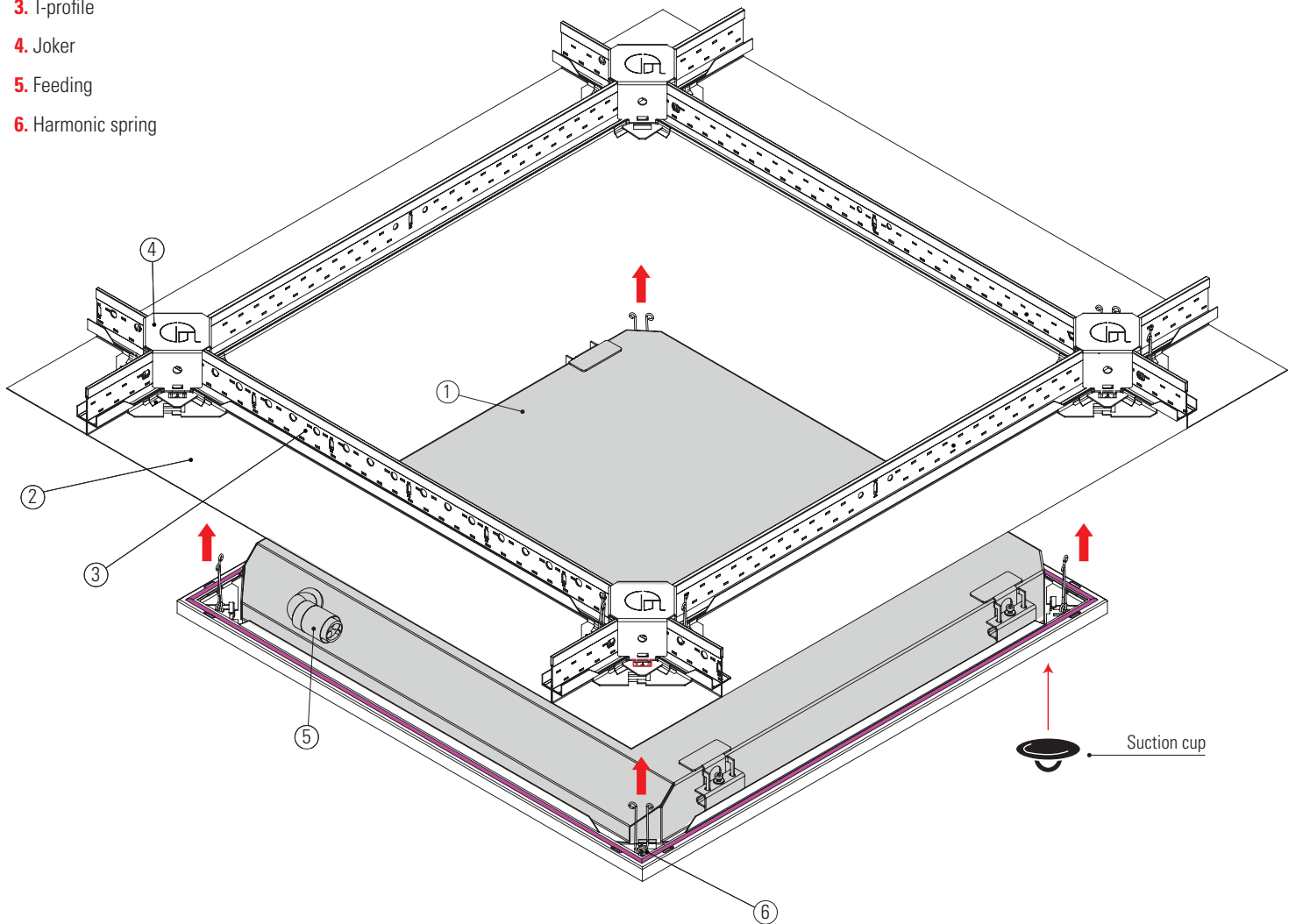

ASSEMBLY DESCRIPTION

Vert Lab Light is assembled in the same way as a Vert Lab panel, the steps are few and intuitive:

1. Tighten the springs(6) located at the four corners of the ceiling light.
2. Insert the springs into the slot of the Jokers(4) located on each junction of the T-structure.
3. Then connect to the mains using the power supply socket(5).

- Push the ceiling light up to complete the assembly.

- To inspect the ceiling light use the suction cup in the corner

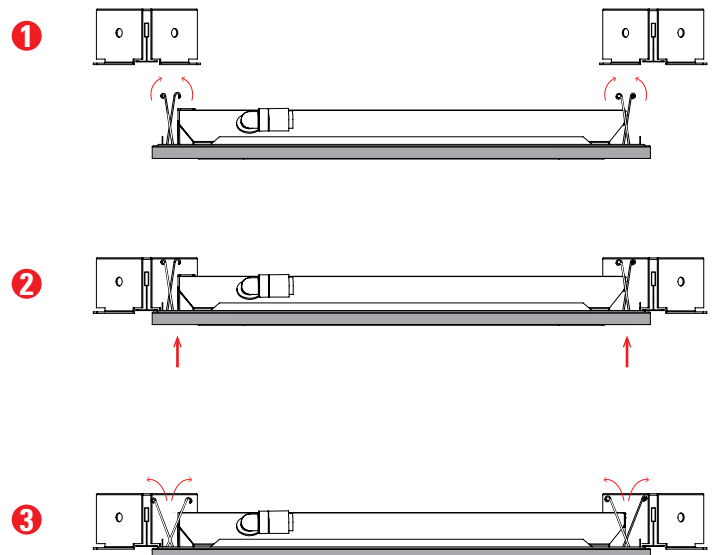

VIEW POSITIONING FROM ABOVE

EXAMPLE OF MOUNTING ON T-FRAME

SYSTEM ELEMENTS

- 1. Vert Lab Light
- 2. Vert Lab Panel
- 3. T-profile
- 4. Joker
- 5. Power supply
- 6. Harmonic spring
- 7. Suspension

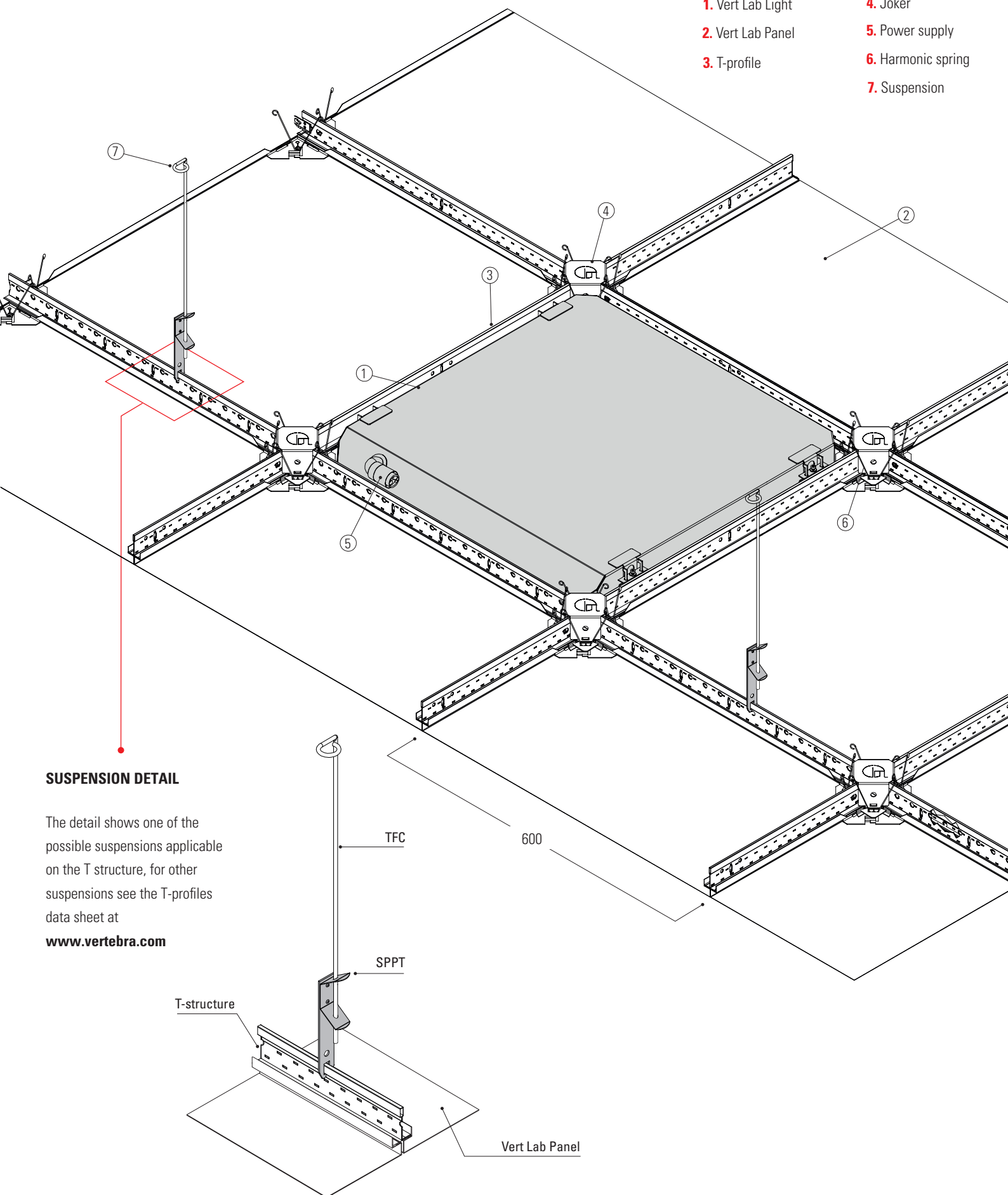

SUSPENSION DETAIL

The detail shows one of the possible suspensions applicable on the T structure, for other suspensions see the T-profiles data sheet at

www.vertebra.com

PERIMETER ASSEMBLY WITH VL.PPF

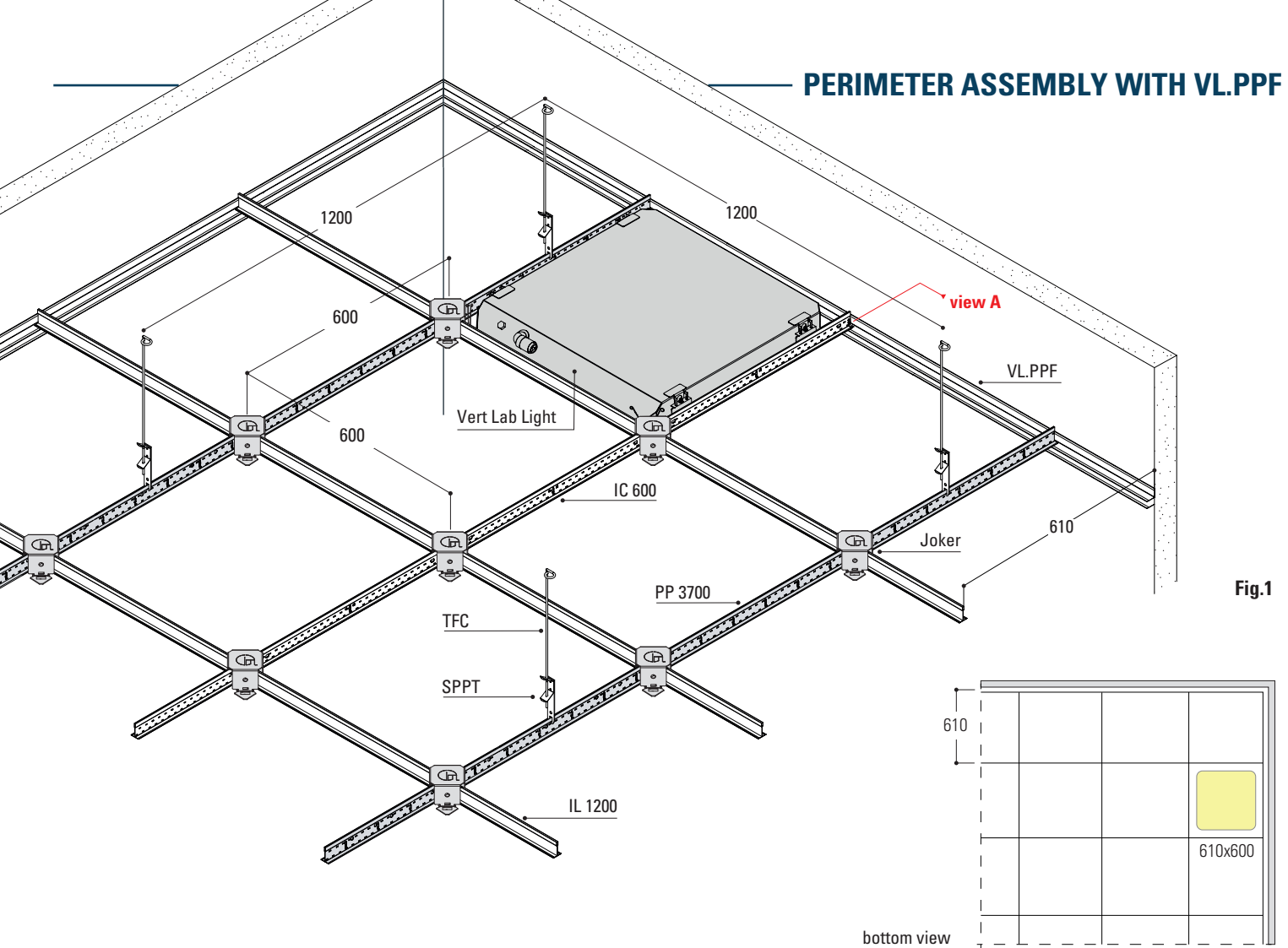

PERIMETER ASSEMBLY WITH VL.PPF

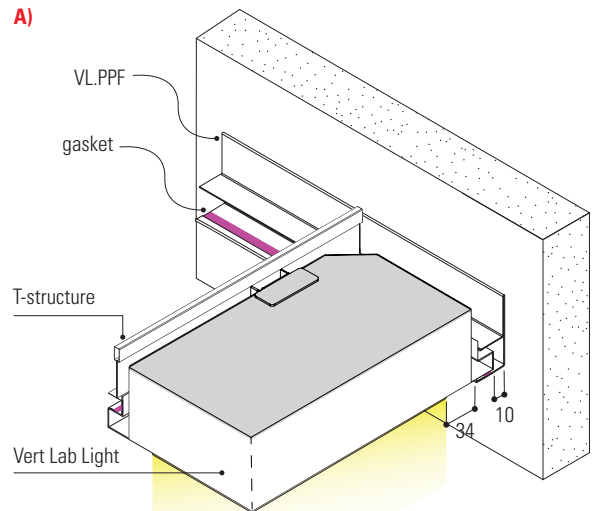
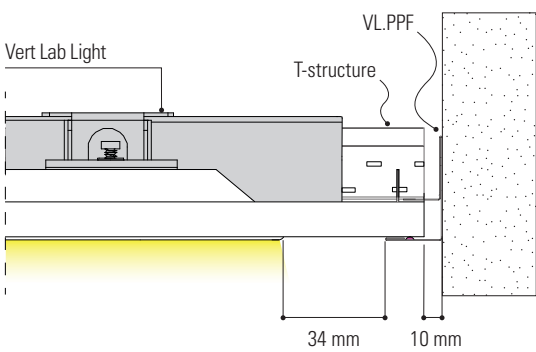

DESCRIPTION:

Vert Lab Light is mounted in the same way as a normal Vert Lab panel. It is advisable to compress or locally remove the gasket on the edge (perimeter side) of the panel to facilitate insertion; the seal is ensured by the gasket on the base of the perimeter. Installation continues by placing the panel on the underside of the VL.PPF. There will be a gap of 10 mm between the panel and the perimeter profile.

VERT LAB LIGHT MOUNTING ON VL.PPC

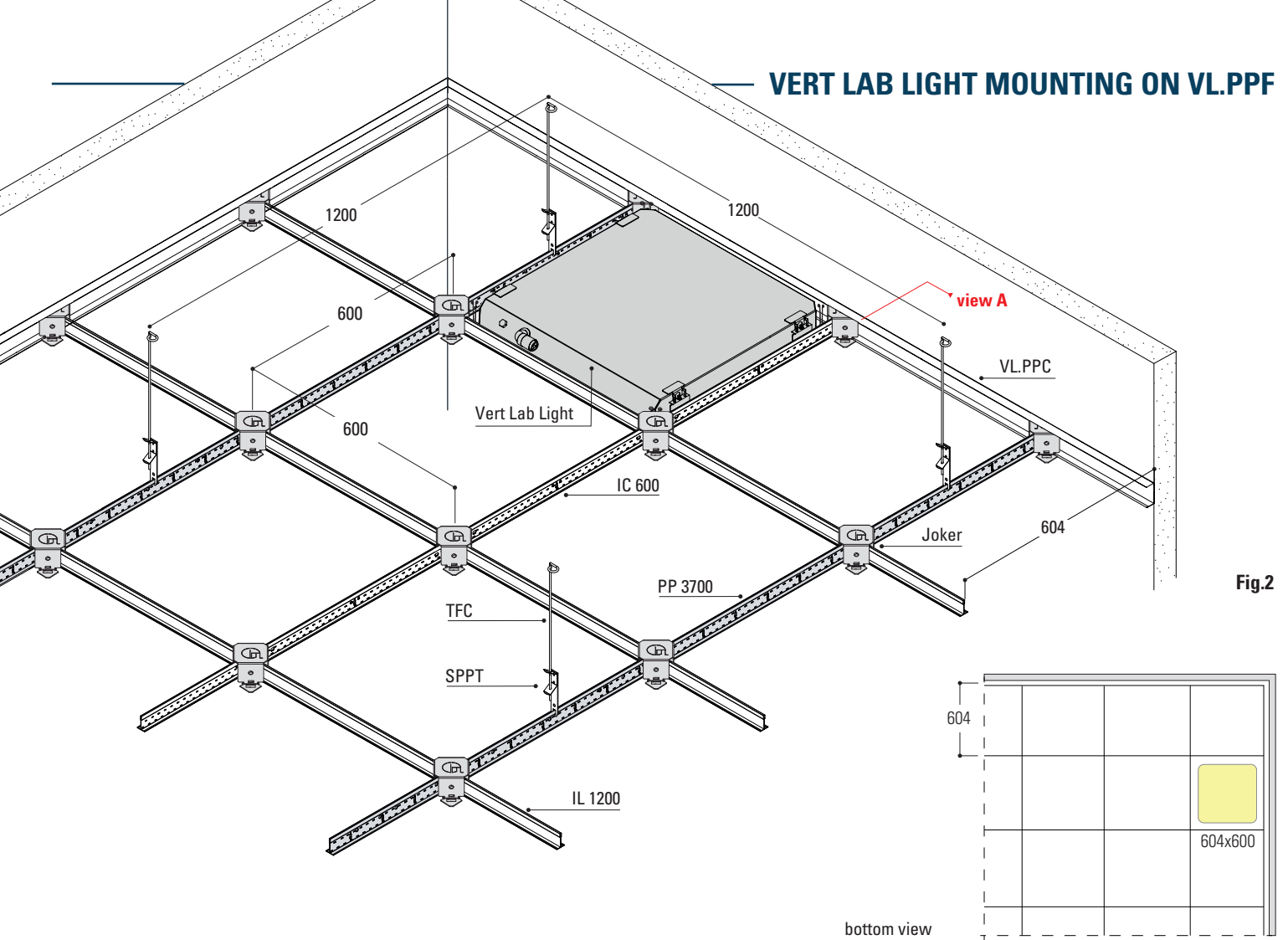

PERIMETER ASSEMBLY WITH VL.PPC

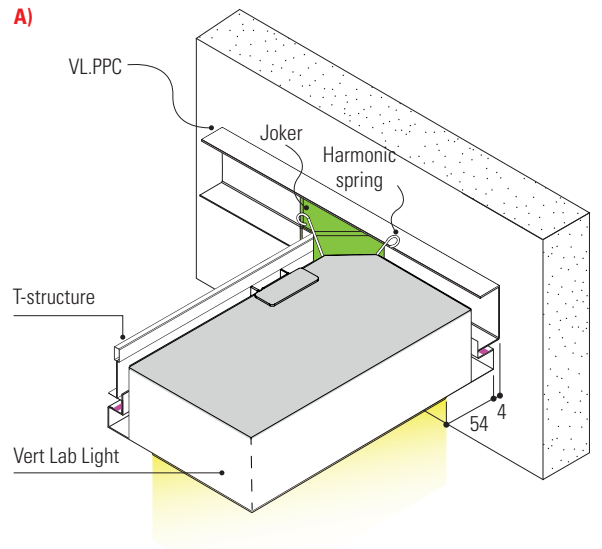
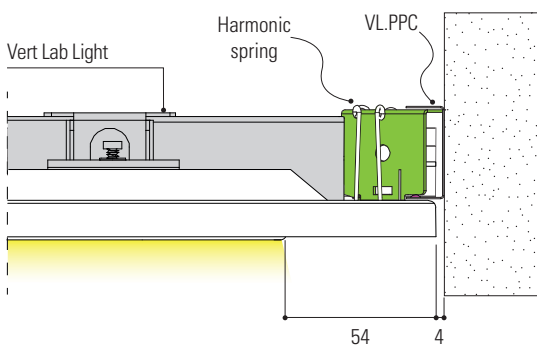

DESCRIPTION:

If Vert Lab Light is to be installed without an exposed perimeter, the VL.PPC perimeter profile must be used. This condition requires that during installation, the height of the T structure is coplanar to the height of the perimeter and that 1/2 Joker is used on the T-structure (see drawings).

PERIMETER ASSEMBLY WITH VL.PDL

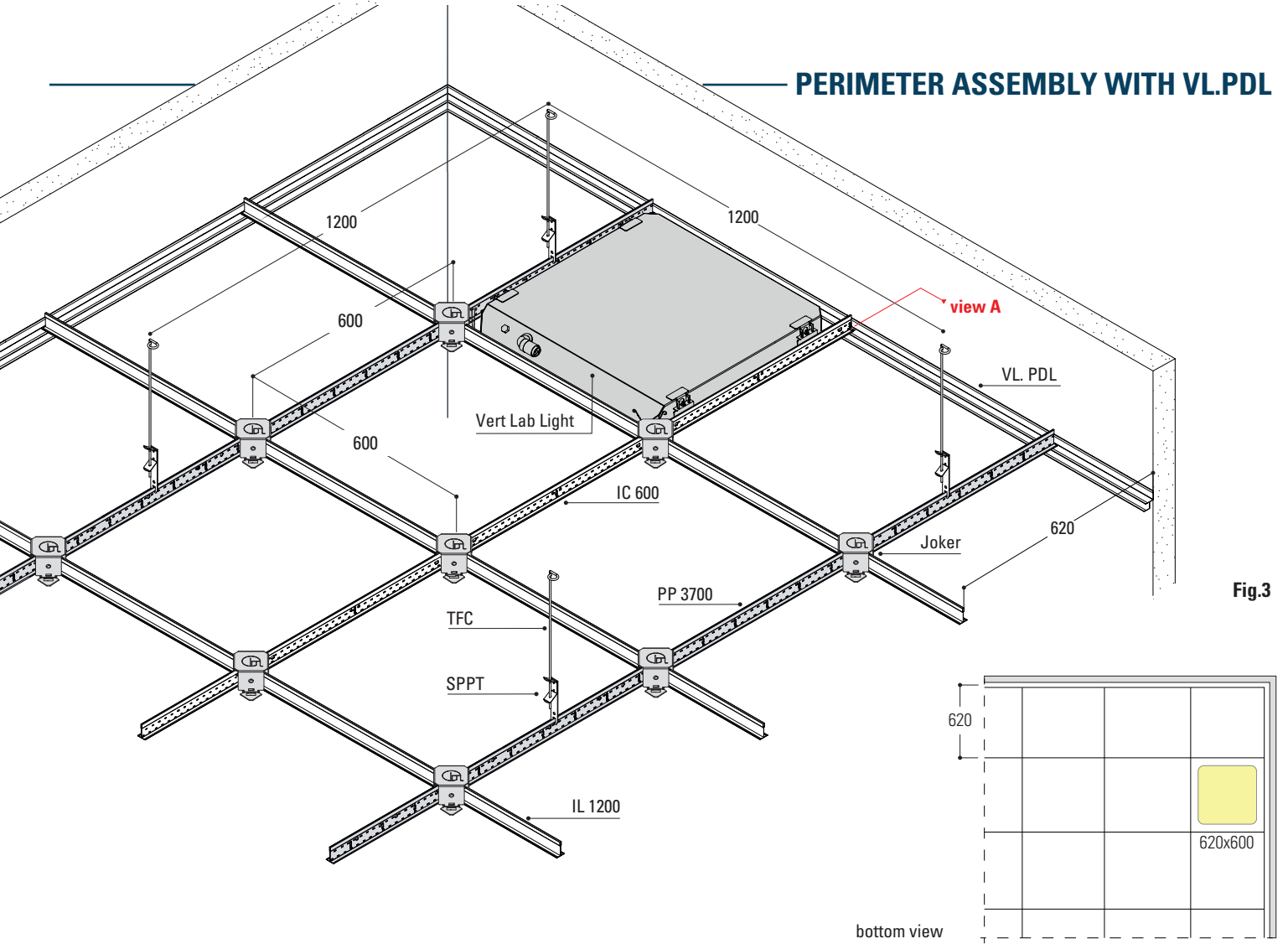

Vert Lab Light assembly on VL.PDL

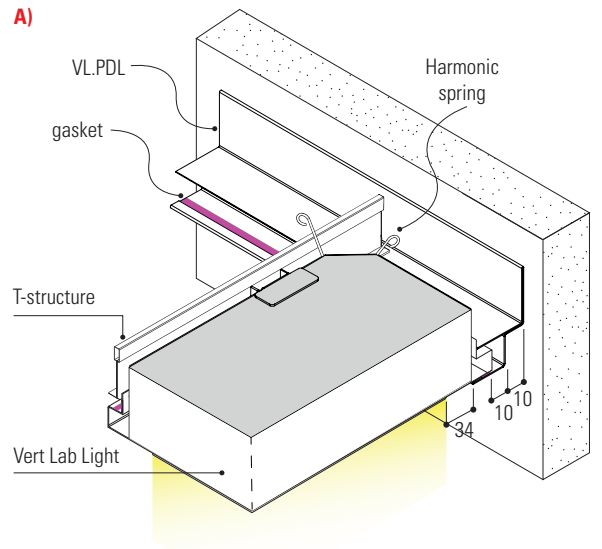
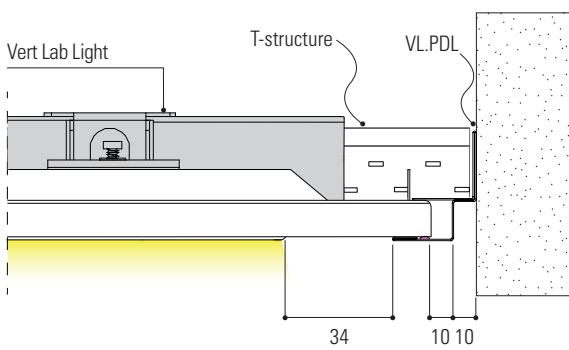

DESCRIPTION:

The installation of Vert Lab Light on the VL.PDL perimeter has as its main feature that of creating a 10 mm shutter along the entire perimeter. The assembly is almost identical to the VL.PPF perimeter, continuing with the structure resting on the upper side of the profile and the panel resting on the lower side of the perimeter.

POWER SUPPLY SOCKET AND SEAL

A: POWER SUPPLY

230/240 - 50/60 Hz power supply with 0.75 mm² cross-section cable and PVC-HT sheathing flame retardant in accordance with CEI 20-35 and complying with CEI 20.20 and CEI CENELEC HD 21 standards. IP66 watertight connector 2P+E or 4P+E, maximum allowed cable cross-section 2.5 mm². Insulation class I. Suitable for installation on normally flammable surfaces.

- Power supply EEI=A2 230-240, 50 - 60Hz. power factor > 0.95.

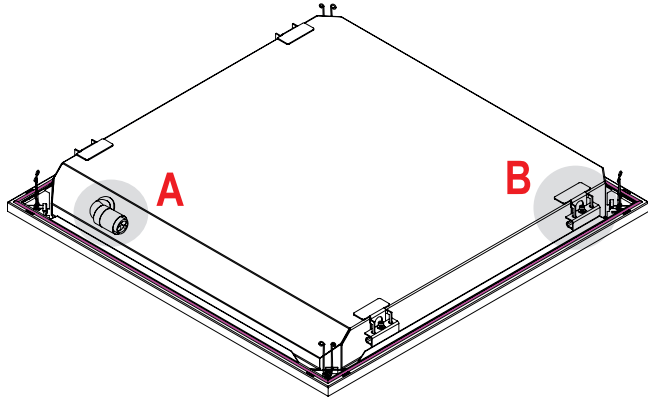

B: CLOSING BRACKET AND SEAL

Closing bracket consisting of two parts :

- Upper bracket
- Lower sealing bracket on which the guarantee seal is affixed.

It is recommended not to remove the seal, as this would result in the loss of the product warranty.

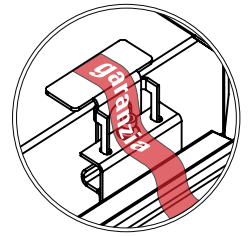

OTHER EQUIPMENT

Possible equipment of the Microprocessor Self-Test Module equipped with:

- Autonomy test
- Functionality test
- Routine tests

**Luminous flux tolerance $\pm 10\%$.

*Dual Power possibility

*RGB - DMX/ DALI system with localised touch panel

**Power subject to minor ($\pm 5\%$) variations without notice

*/** see table page 2

WARNINGS

General Warnings

- The luminaire is constructed in a workmanlike manner, and its electrical life will be more than sufficient if used correctly.
- Please read the following warnings carefully as they are important information for safe installation, use and maintenance.
- After removing the appliance from its packaging, ensure that it is undamaged, otherwise contact the seller.
- Packaging elements (plastic bags etc.) must not be left within reach of children as they are potential sources of danger.
- Before connecting the appliance, make sure that the rating plate data correspond to those of the electrical distribution network to which the appliance will be connected (the label with the rating plate data is located on the outside of the appliance).
- Before carrying out any cleaning or maintenance operations, disconnect the appliance from the mains power supply by switching off the circuit breaker; in the event of a fault, contact only professionally qualified personnel.
- Failure to do so may compromise the safety of the appliance.
- The manufacturer cannot be held liable for any damage resulting from improper, incorrect and unreasonable use.

Important warnings

- The product must not be subject to modification, any modification voids the warranty and may render the product dangerous.
- Antonio Guersasio s.r.l. shall not be held liable for any damage caused by its products not being assembled in accordance with the instructions.
- Any damaged components must be replaced with similar ones.
- The products must be installed in a workmanlike manner.
- In order to avoid dangerous overheating, it is recommended not to install the appliance in cramped spaces without air exchange.
- The appliance is also intended for installation on normally flammable surfaces.

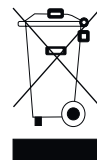

Recycling

In implementation of Directives 2002/95/EC, 2002/96/EC and 2003/108/EC ("on the reduction of the use of hazardous substances in electrical and electronic equipment and the disposal of waste") the crossed-out wheeled bin serves as a reminder to collect the product separately from other waste at the end of its life or to return it to the retailer when purchasing a new appliance of an equivalent type. This helps to preserve the environment from contamination and promotes the recycling of equipment components. Unauthorised disposal is subject to sanctions in accordance with the law.



IP66

